

SCREWLINE4

Water-cooled liquid chiller for indoor installation
Capacity from 572 to 1499 kW

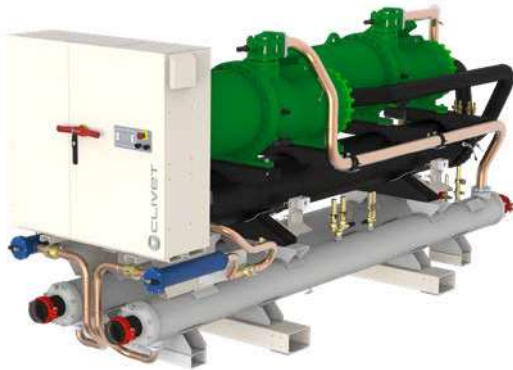

Clivet participates in the EUROVENT "Liquid Chilling Packages and Hydronic Heat Pumps".
Check ongoing validity of certificate on www.eurovent-certification.com



Cooling only



Heating only



Water cooled



Indoor installation



R-134a



Semi-hermetic Twin-screw



Reversible water circuit



Electronic expansion valve



Intelliplant



ErP compliant

- ✓ Double independent circuits for high reliability with screw compressors
- ✓ First investment driven and refurbishment applications
- ✓ Refrigerant R134a - GWP = 1430
- ✓ 3 operating modes: Cooling only, Heating only, Operation with water circuit change-over
- ✓ Two acoustic configurations: standard and super-silenced
- ✓ Modular operation management, up to 7 units in cascade
- ✓ Integrated partial and total recovery
- ✓ Condenser water temperature up to 65°C with heating only version (OHO), evaporator water temperature down to -8°C

Versions and configurations

VERSION:

EXC Excellence (Standard)

LOW TEMPERATURE:

- Low temperature: not required (Standard)
B Water low temperature

OPERATION:

OCO Cooling-only operation (Standard)
OHO Heating-only operation
OHI Operation with water circuit change-over

CONFIGURAZIONE ACUSTICA:

ST Standard acoustic configuration (Standard)
EN Supersilenced acoustic configuration

RECUPERO ENERGETICO:

- Energy recovery: not required (Standard)
D Partial energy recovery
R Total energy recovery

VERSIONE ALTA TEMPERATURA ACQUA:

HWT High water temperature

Dimensions and connections

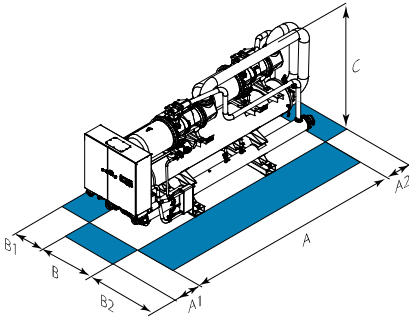

Size	▶▶ WDH-SB4	220.2	240.2	280.2	320.2	360.2	440.2	500.2	540.2	580.2
A - Length	mm	4766	4766	4766	4785	4785	5028	5147	5147	5147
B - Width	mm	1408	1408	1408	1408	1408	1408	1408	1408	1408
C - Height	mm	2033	2033	2033	2183	2183	2182	2308	2308	2308
A1	mm	1470	1470	1470	1470	1470	1470	1470	1470	1470
A2	mm	700	700	700	700	700	700	700	700	700
B1	mm	1000	1000	1000	1000	1000	1000	1000	1000	1000
B2	mm	1000	1000	1000	1000	1000	1000	1000	1000	1000
Operating weight	mm	4099	4119	4156	5854	5874	6004	6453	6681	6761

The above mentioned data are referred to standard units for the constructive configurations indicated. For all the other configurations, refer to the relative Technical Bulletin.

CAUTION!
For trouble-free operation of the unit it is essential to maintain the safety distances indicated by the blue areas.

Technical data

Size		WDH-SB4	220.2	240.2	280.2	320.2	360.2	440.2	500.2	540.2	580.2
Cooling capacity (EN 14511:2022)	(1)	kW	572	613	706	867	978	1124	1299	1369	1499
Total power input (EN 14511:2022)	(1)	kW	109	120	138	164	188	213	244	273	304
EER (EN 14511:2022)	(1)	-	5,25	5,11	5,11	5,27	5,20	5,29	5,32	5,02	4,93
SEER	(4)	-	6,43	6,53	6,52	6,47	6,38	6,43	6,44	6,38	6,38
$\eta_{s,c}$	(4)	%	254,3	258,2	257,8	255,9	252,3	254,4	254,5	252,3	252,3
Heating capacity (EN 14511:2022)	(2)	kW	716	768	939	1033	1179	1454	1592	1740	1858
Total power input (EN 14511:2022)	(2)	kW	144	155	189	206	237	293	322	351	379
COP (EN 14511:2022)	(2)	-	4,97	4,95	4,97	5,00	4,97	4,96	4,94	4,96	4,90
Refrigeration circuits		Nr	2								
No. of compressors		Nr	2								
Type of compressors		-	SCREW								
Refrigerant		-	R-134a								
Water flow-rate (User side)		l/s	27,2	29,2	33,6	41,2	46,5	53,4	61,7	65,1	71,2
Water flow (Source side)		l/s	32,7	35,1	40,4	49,4	55,9	64,0	73,9	78,7	86,3
Standard power supply		V	400/3~/50								
ST Sound power level	(3)	dB(A)	99	100	100	101	101	103	103	105	105
EN Sound power level	(3)	dB(A)	95	96	96	98	98	100	100	101	101

(1) Performance data calculated in accordance with EN 14511:2022 referred to the following conditions: Internal exchanger water temperature = 12/7°C; External exchanger water temperature = 30/35°C
 (2) HWT Version: Performance data calculated in accordance with EN 14511:2022 referred to the following conditions: Internal exchanger water temperature = 40/45°C; External exchanger water temperature = 10/7°C
 (3) Sound pressure levels are referred to units operating at nominal load in nominal conditions. Measurements are carried out accordingly to UNI EN ISO 9614-1 at nominal standard conditions defined in respective regulations: EU 2016/2281, UE 813/2013, UE 811/2013.

Sound power level are not Eurovent certified.
 (4) Data calculated according to the EN 14825:2022 Regulation

The Product is compliant with the Erp (Energy Related Products) European Directive. It includes the Commission delegated Regulation (EU) No 2016/2281, also known as Ecodesign Lot21.

Accessories

SPC1	Set point compensation with 4-20 mA signal	CMSC10	Serial communication module for LonWorks supervisor
SCP4	Set-point compensation with 0-10 V signal	CMSC11	Serial communication module for BACnet-IP supervisor
SPC2	Set-point compensation with outdoor air temperature probe	RPR	Refrigerant leak detector
IVMSX	Source side 2-way modulating valve	ECS	ECOSHARE function for the automatic management of a group of units
CONTA2	Energy meter	CBS	Overload circuit breakers
IFWX	Steel mesh filter on the water side	RDVS	Switching valve with double safety valves
AMRX	Rubber antivibration mounts	MHP	High and low pressure gauges
RCMRX	Remote control via microprocessor control	CO2P	2 pass condenser
PSX	Mains power supply	IOTX	IoT industrial module for cloud based interoperability & services
SFSTR2	Progressive compressor start-up device		
PFPC	Power factor correction capacitors (cosfi > 0.9)		
CMSC9	Serial communication module for Modbus supervisor		

Accessories whose code ends with "X" are supplied separately